

VisiSight Photoelectric Sensors

Catalog Numbers 42JS-B2MNB1-x, 42JS-B2MNB2-x, 42JS-B2MPB1-x, 42JS-B2MPB2-x, 42JS-D2MNA1-x, 42JS-D2MNA2-x, 42JS-D2MPA1-x, 42JS-D2MPA2-x, 42JS-E1EZB1-x, 42JS-E2EZB1-x, 42JS-P2MNA2-x, 42JS-P2MNB1-x, 42JS-P2MPA2-x, 42JS-P2MPB1-x, 42JS-R9MNA1-x, 42JS-R9MNA2-x, 42JS-R9MPA1-x, 42JS-R9MPA2-x

Topic	Page
Description	1
Features	1
Specifications	1
Sensor Indicators	2
Wiring Diagrams	3
Dimensions	3
Accessories	3
Typical Response Curves	5
Margin Curves	6

Description

The 42JS VisiSight™ family of sensors offers a full range of sensing modes in miniature rectangular housing. Visible light source is offered in all models for ease of alignment. Additional transmitted beam infrared status-indicator source models are offered for excellent crosstalk immunity.

The 42JS VisiSight family provides an indication if the sensor operation is unstable. An indicator flashes if the signal level is too close to the detection threshold. This indicator helps in easy alignment of the sensor and forewarns against detection of a background.

Features

- Visible light source that is offered on all models for ease of alignment
- Optional snap-on adapter for 18 mm mounting
- Patented ASIC design offers linear sensitivity adjustment, stability indication, and excellent noise immunity
- Compact sealed housing and cavity-free design to minimize collection of dust and debris while allowing for easy sensor cleanup
- Threaded metal M12 or M8 connector on pigtail
- 360° visible status indicators
- Additional transmitted beam models available with Infrared light source for excellent cross talk immunity
- Input to disable light source on transmitted beam emitter

Specifications

Attribute	42JS
Environmental	
Operating Environment	IP67
Operating Temperature	-20...+60°C (-4...+140°F)
Vibration	10...55 Hz, 1 mm amplitude; meets or exceeds IEC 60947-5-2
Shock	30 g (1.06 oz) with 1 ms pulse duration; meets or exceeds IEC 60947-5-2
Relative Humidity	5...95% (noncondensing)
Ambient Light Immunity	Incandescent light 5000 Lux

Optical	Standard Diffuse	Background Suppression	Polarized Retro	Transmitted Beam
Sensing Range ¹	800 mm (31.5 in.) ⁴ 250 mm (9.8 in.) ⁵	6...55 mm (0.24...2.17 in.) ² 2...130 mm (0.07...5.12 in.) ³	30 mm...3.0 m (1.18 in...9.84 ft)	10 m (32.8 ft)
Field of View	4° ⁴ 5.5° ⁵	14° ² 17° ³	2.8°	4°
Spot Size at max. rated range	60 mm (2.36 in.) ⁴ 40 mm (1.57 in.) ⁵	7.6 mm (0.30 in.) @ 55 mm (2.16 in.) ² 11.5 mm (0.45 in.) @ 130 mm (5.12 in.) ³	175 mm (6.89 in.)	700 mm (27.56 in.)
Light Source	Visible red (645 nm)			Visible red (645 nm) & Infrared (850 nm)
Sensitivity Adjustments	Single-turn potentiometer	No adjustment	Single-turn potentiometer adjustment and no adjustment models	Single-turn potentiometer

Electrical	
Voltage	10...30V DC
Current Consumption	25 mA
Protection	Short circuit, overload, false pulse, transient noise, reverse polarity

Outputs	
Response Time	1 ms
Output Type	PNP or NPN by cat. no.
Output Mode	Complementary light and dark operate
Output Current	100 mA
Output Leakage Current	10 µA max

Mechanical

Housing Material	ABS
Lens Material	PMMA
Cover Material	PMMA
Connection Types	2 m (6.5 ft) cable, 4-pin DC micro (M12) QD, 4-pin pico (M8) QD
Supplied Accessories	Mounting hardware (M3x25) stainless steel screws
Optional Accessories	Snap-on adapter for 18 mm mounting (IP40), mounting brackets, cordsets, reflectors

¹ See Typical Response Curves for sensing range with the 18 mm (0.71 in.) mounting adapter.

² For 55 mm (2.16 in.) background suppression models (42JS- B2MNB1- F4 and 42JS- B2MPB1- F4).

³ For 130 mm (5.12 in.) background suppression models (42JS- B2MNB2- F4 and 42JS- B2MPB2- F4).

⁴ For 800 mm (31.49 in.) diffuse models (42JS- D2MNA1- F4 and 42JS- D2MPA1- F4).

⁵ For 250 mm (9.8 in.) diffuse models (42JS- D2MNA2- F4 and 42JS- D2MPA2- F4).

Sensor Indicators

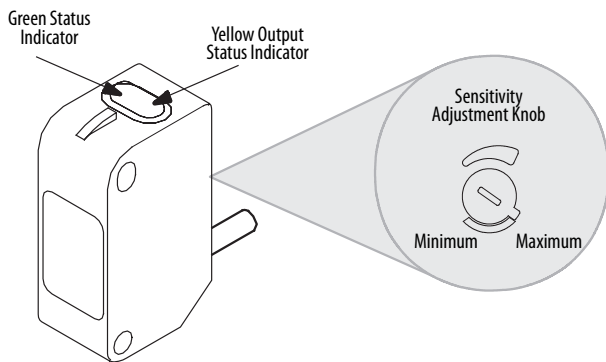

Indicator Status

Indicator Color	State	Function
Green	OFF	Power is Off
	ON	Power is On
	Flashing (6 Hz)	Unstable ($0.5 < \text{Margin} < 2$)
	Flashing (1.5 Hz)	Output short circuit protection active
Yellow	OFF	Output de-energized ⁶
	ON	Output energized ⁶

⁶ Black wire or pin four of connector.

Background Suppression Sensors

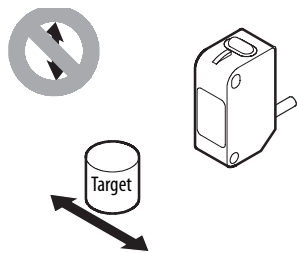

IMPORTANT Due to the detection method, targets traveling horizontally to the sensor optics are detected. Targets traveling vertically cannot be accurately detected. For excellent reliable background suppression, a minimum separation distance of 6 mm (0.24 in.) is recommended between the target and the background.

Sensor Alignment

1. Verify that the sensitivity knob is set at its maximum (factory default) setting.
2. Pan the sensor to the left, right, up, and down to center the beam on the sensed object (for diffuse), reflector (for retroreflective), or transmitter (for transmitted beam). Affix the sensor position when the green status indicator is ON (not flashing) and the yellow output indicator is ON (light sensed and L.O. output energized). This configuration assures a good margin and that the signal received is greater than twice the signal that is required to energize the L.O. output.
3.
 - a. For diffuse applications, remove the object being sensed and observe the green status indicator. If the green indicator is flashing (at 6 Hz), the sensor is receiving more than half the signal required to energize the L.O. output when there can be minimal or no received signal. It indicates that the sensor is getting close to detection of the background. Stability can be optimized by reducing the reflectivity of the background or reducing the sensitivity. Reduce the sensitivity to shorten the sensing range. If sensitivity is reduced, check that both the green and yellow indicators are on when the object is detected (step 2). In applications where the full range is needed, for example, sensitivity cannot be reduced, the green indicator can be left flashing.
 - b. For retroreflective and transmitted beam applications, place the object to be sensed in the beam path and observe the green indicator. If the green indicator is flashing (at 6 Hz), that sensor is receiving more than half the signal required to energize the L.O. output when there can be minimal or no signal received. It indicates that the object being detected is letting some light go through (semi-transparent or too small). Adjust sensitivity and repeat step 2.

Crosstalk Avoidance

For applications of transmitted-beam sensors which require adjacent pairs to be mounted close, use the red indicator and infrared indicator pairs as adjacent pairs.

The following spacing (center to center) between the adjacent pairs can be maintained to avoid crosstalk:

1. Red indicator pair that is adjacent to the infrared indicator pair:
 - a. 60 mm (2.4 in.) for sensing range up to 1.6 m (4.8 ft)
 - b. 20 mm (0.8 in.) for sensing range greater than 1.6 m (4.8 ft)
2. Two adjacent pairs of red indicator models or two adjacent pairs of infrared indicators: 360 mm (14 in.).

Two pairs of red indicators or two pairs of infrared indicators can be mounted adjoining each other by transposing the emitter and receiver positions of the second pair vs. the first pair. There is no crosstalk as each receiver only receives signal from one emitter.

Mounting the Sensor

Securely mount the sensor on a firm, stable surface, or support. An application that is subject to excessive vibration or shifting can cause intermittent operation. Adapters and mounting brackets are available for a flexible installation that can include vibration and shock while shifting. See [Accessories on page 3](#) for more details.

Wiring Diagrams

Cable connection is shown in the following diagrams. Pin numbers correspond to an M12 or M8 male connector on the sensor.

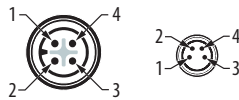

PNP Models with Complementary Outputs

PNP Models with Complementary Outputs

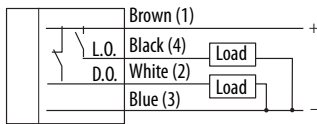

NPN Models with Complementary Outputs

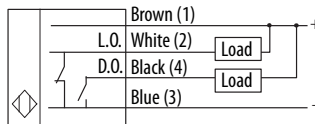

Transmitted Beam Emitter

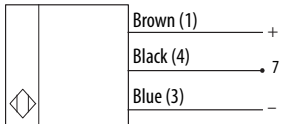

⁷ For normal operation, black wire (pin 4) needs no connection. To disable light source, connect black wire (pin 4) to +V.

Approximate Dimensions [mm (in.)]

IMPORTANT To avoid damage to the sensor or mounting adapter, follow the torque specifications.

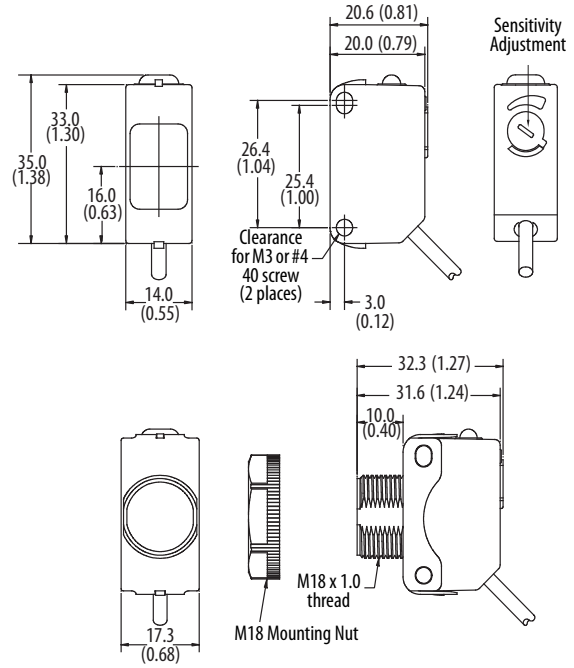

Accessories

The sensor can be mounted using an 18 mm snap-on adapter⁸ (60-AJS-18) as shown. Align the slotted hole with the slotted hole on the sensor and snap on.

To remove the sensor from the adapter, undo the snap by using a flat screwdriver.

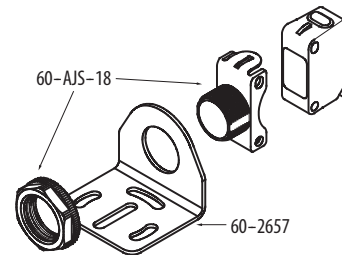

⁸ Damage can occur to snap-on adapter if torque above 1.69 N·m (15 in·lb) is applied to the 18 mm mounting nut.

Mounting Bracket—60-BJS-L1⁹

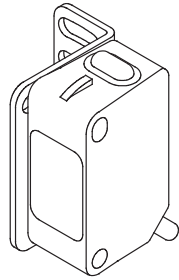
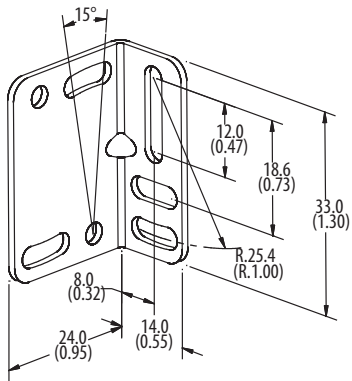

Swivel/Tilt Mounting

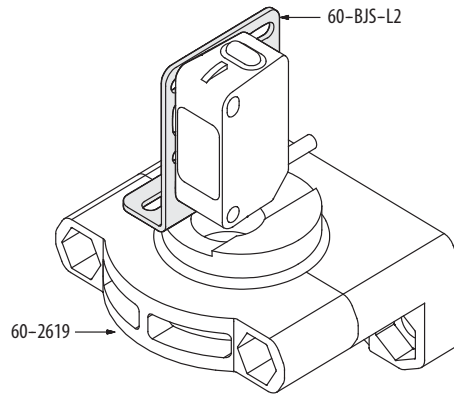

⁹ In high vibration applications, use mounting hardware that is supplied with the sensor to attach the 18 mm adapter to the sensor.

Mounting Bracket—60-BJS-L2¹⁰

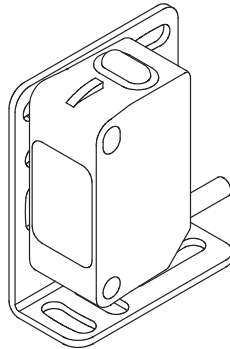
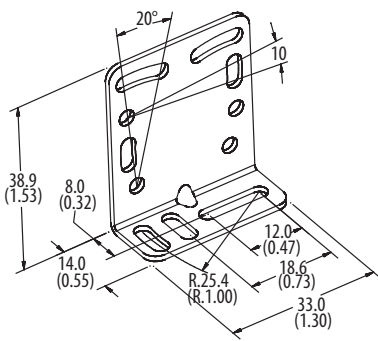

¹⁰ Damage can occur to the sensor housing if torque above 0.28 N·m (2.5 in-lb) is applied to the mounting screws.

Typical Response Curves

Standard Diffuse

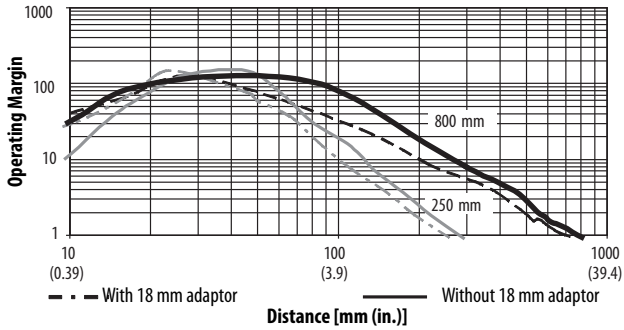

Standard Diffuse—Beam Pattern

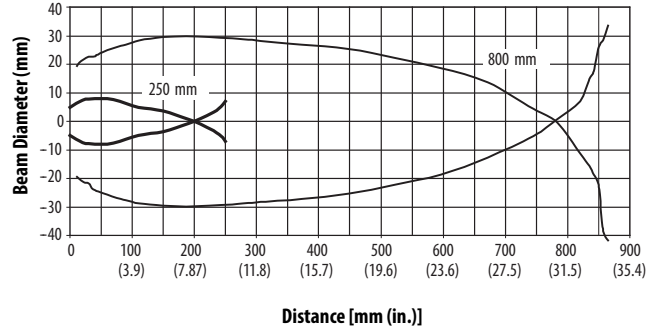

Background Suppression (55 mm)

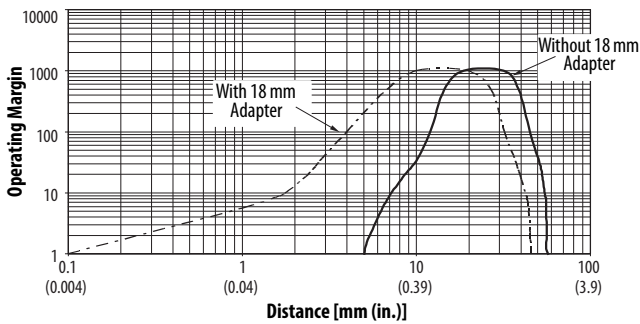

Background Suppression (55 mm)—Beam Pattern

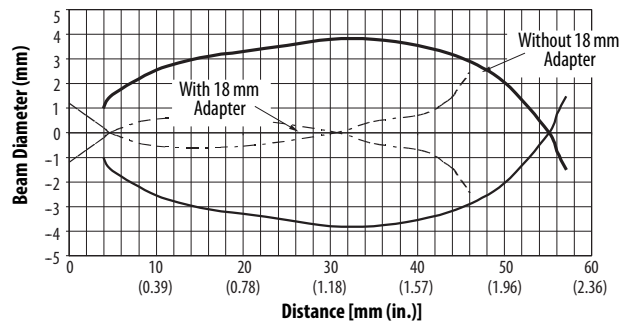

Background Suppression (130 mm)

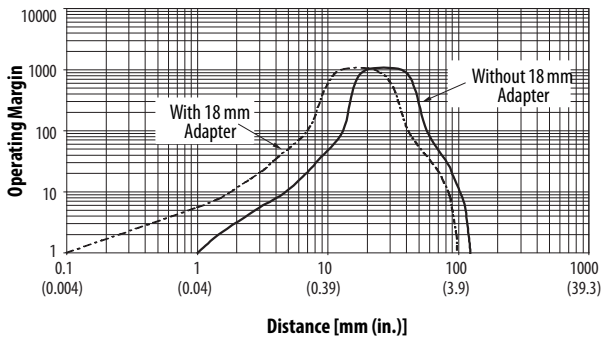

Background Suppression (130 mm)—Beam Pattern

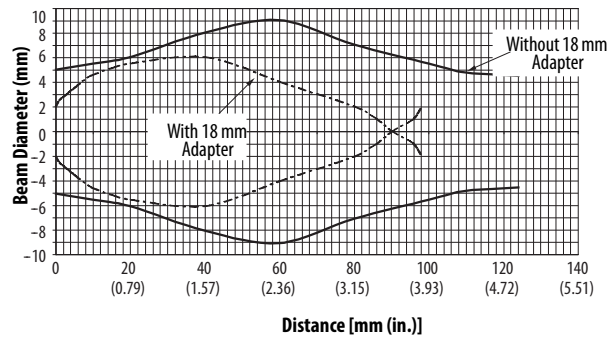

Transmitted Beam—Visible Red and Infrared

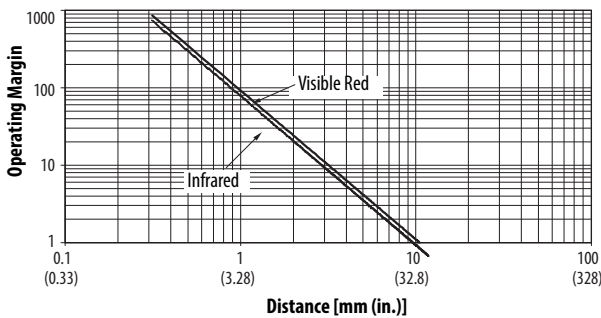

Transmitted Beam—Beam Pattern

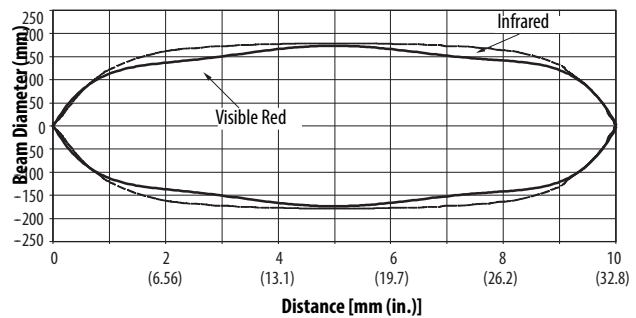

Margin Curves

Polarized Retroreflective

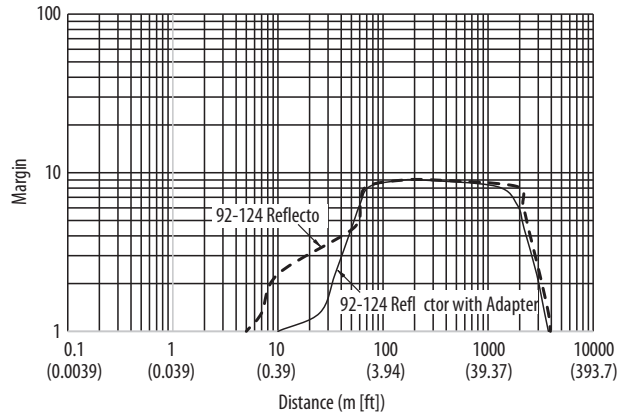

Polarized Retroreflective

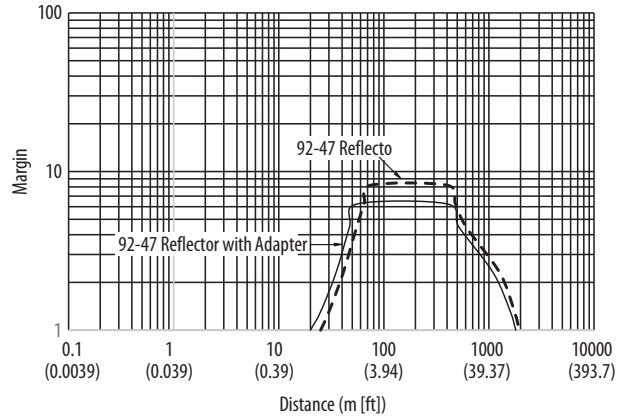

Polarized Retroreflective

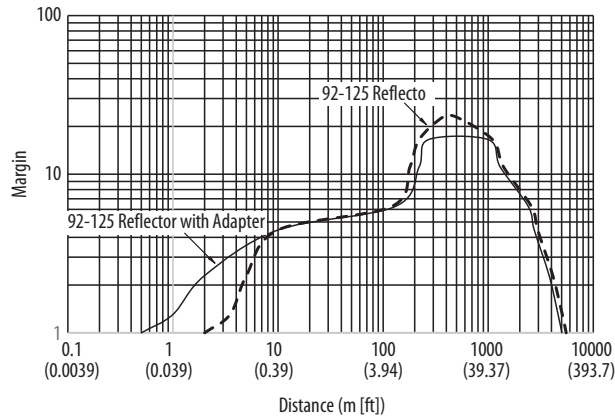

Polarized Retroreflective Beam Patterns

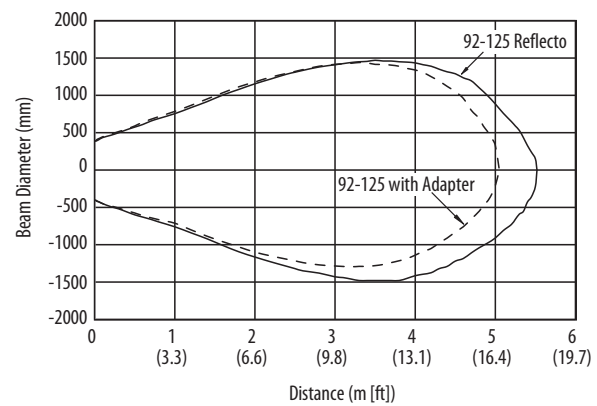
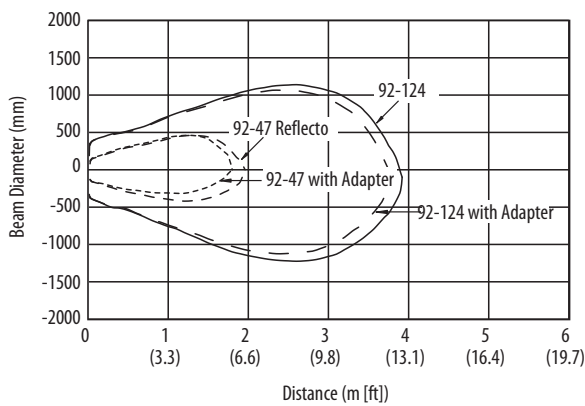

Notes:

Rockwell Automation Support

Use the following resources to access support information.

Technical Support Center	Knowledgebase Articles, How-to Videos, FAQs, Chat, User Forums, and Product Notification Updates.	https://rockwellautomation.custhelp.com/
Local Technical Support Phone Numbers	Locate the phone number for your country.	http://www.rockwellautomation.com/global/support/get-support-now.page
Direct Dial Codes	Find the Direct Dial Code for your product. Use the code to route your call directly to a technical support engineer.	http://www.rockwellautomation.com/global/support/direct-dial.page
Literature Library	Installation Instructions, Manuals, Brochures, and Technical Data.	http://www.rockwellautomation.com/global/literature-library/overview.page
Product Compatibility and Download Center (PCDC)	Get help determining how products interact, check features and capabilities, and find associated firmware.	http://www.rockwellautomation.com/global/support/pcdc.page

Documentation Feedback

Your comments will help us serve your documentation needs better. If you have any suggestions on how to improve this document, complete the How Are We Doing? form at http://literature.rockwellautomation.com/idc/groups/literature/documents/du/ra-du002_-en-e.pdf.

Rockwell Automation maintains current product environmental information on its website at <http://www.rockwellautomation.com/rockwellautomation/about-us/sustainability-ethics/product-environmental-compliance.page>.

Allen-Bradley, Rockwell Automation, Rockwell Software, and VisiSight are trademarks of Rockwell Automation, Inc. Trademarks not belonging to Rockwell Automation are property of their respective companies.

Rockwell Otomasyon Ticaret A.Ş., Kar Plaza İş Merkezi E Blok Kat:6 34752 İçerenköy, İstanbul, Tel: +90 (216) 5698400

www.rockwellautomation.com

Power, Control and Information Solutions Headquarters

Americas: Rockwell Automation, 1201 South Second Street, Milwaukee, WI 53204-2496 USA, Tel: (1) 414.382.2000, Fax: (1) 414.382.4444
Europe/Middle East/Africa: Rockwell Automation NV, Pegasus Park, De Kleetlaan 12a, 1831 Diegem, Belgium, Tel: (32) 2 663 0600, Fax: (32) 2 663 0640
Asia Pacific: Rockwell Automation, Level 14, Core F, Cyberport 3, 100 Cyberport Road, Hong Kong, Tel: (852) 2887 4788, Fax: (852) 2508 1846
Publication 42JS-IN001B-EN-P - January 2017